

### The 5000 Series ... the ultimate speaker system.

The 5000 Series speakers were designed for the professional contractor or touring professional requiring high power, extremely accurate sound reinforcement. Only the finest components and materials are utilized in the manufacture of this series.

### Cabinetry

The cabinet design uses a 13 ply (18mm) high quality Baltic Birch® plywood with dado joints, recessed baffle and a 16 gauge front perforated grill for long lasting durability. Waterproof adhesive is utilized for lasting durability under the most adverse conditions. The baffle is 1.5" in thickness to enhance acoustical properties and to give the components a rigid interface. For lasting appearance the cabinet is finished with Polane-T® texture coating.

### Electrical Connections

Two Neutrik Speakon connectors are installed on all speakers in the 5000 series. The 5115APT is bi-amp capable with a switch mounted on the jackplate to bypass the internal passive crossover, if needed.

### Transducers

The 5115APT is loaded with a 15" co-axial driver yielding excellent power and phase coherency.

### Specifications

|                                    |                          |
|------------------------------------|--------------------------|
| <b>Frequency Response:</b>         | 40hz-18Khz               |
| <b>Power Handling:</b>             | 600w rms / 1200w program |
| <b>Sensitivity (1 watt/meter):</b> | 96dB                     |
| <b>Nominal Dispersion:</b>         | 90v x 90h                |
| <b>Impedance:</b>                  | 8 Ohms                   |
| <b>Transducer Components</b>       |                          |

|                           |                                |
|---------------------------|--------------------------------|
|                           | 15" woofer                     |
|                           | 2" co-axial HF driver          |
| <b>Input Connections:</b> | Two Neutrik Speakon connectors |
| <b>Bi-Amp Capable:</b>    | Yes                            |
| <b>Enclosure:</b>         | Vented                         |
| <b>Crossover:</b>         | 4th Order LR                   |

### Physical

|                                |                            |
|--------------------------------|----------------------------|
| <b>Dimensions (H x W x D):</b> | 23" x 23" x 19.5"          |
|                                | (58.4cm x 58.4cm x 49.5cm) |
| <b>Weight:</b>                 | 76 lbs./34.6 Kg            |

### Warranty Information

The 5000 Series high definition speakers feature a 3 year warranty. Please refer to the warranty information card shipped with all Sound•Bridge speaker products.

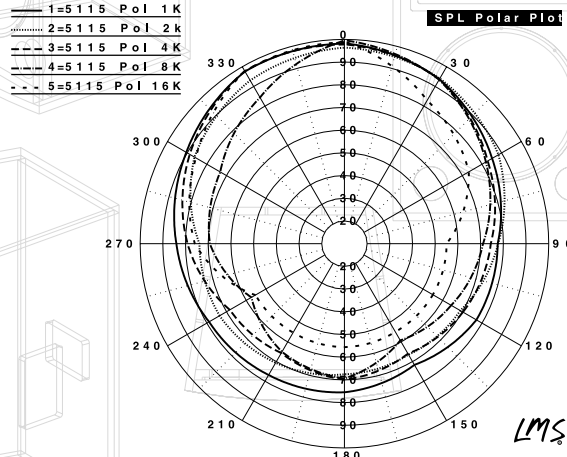
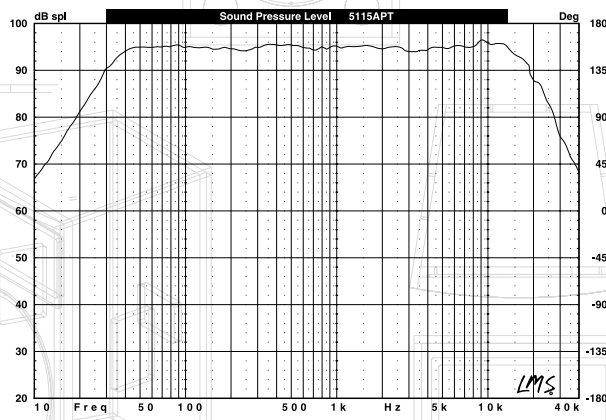

3501 Interstate 35E • Waxahachie, TX • 800 628-9084 • FAX (972) 935-0539

Sound Bridge Acoustic Labs is dedicated to excellence. Therefore, we retain the right to improve design, materials and workmanship. (Or in legal jargon: Prices and Specifications are subject to change without notice.)